

LOC		DIST		REVISIONS			
AD	00	REV	DATE	BY	CHK	APPV	
P2		REVISED PER ECO-08-009171	22APR08	DH		AS	

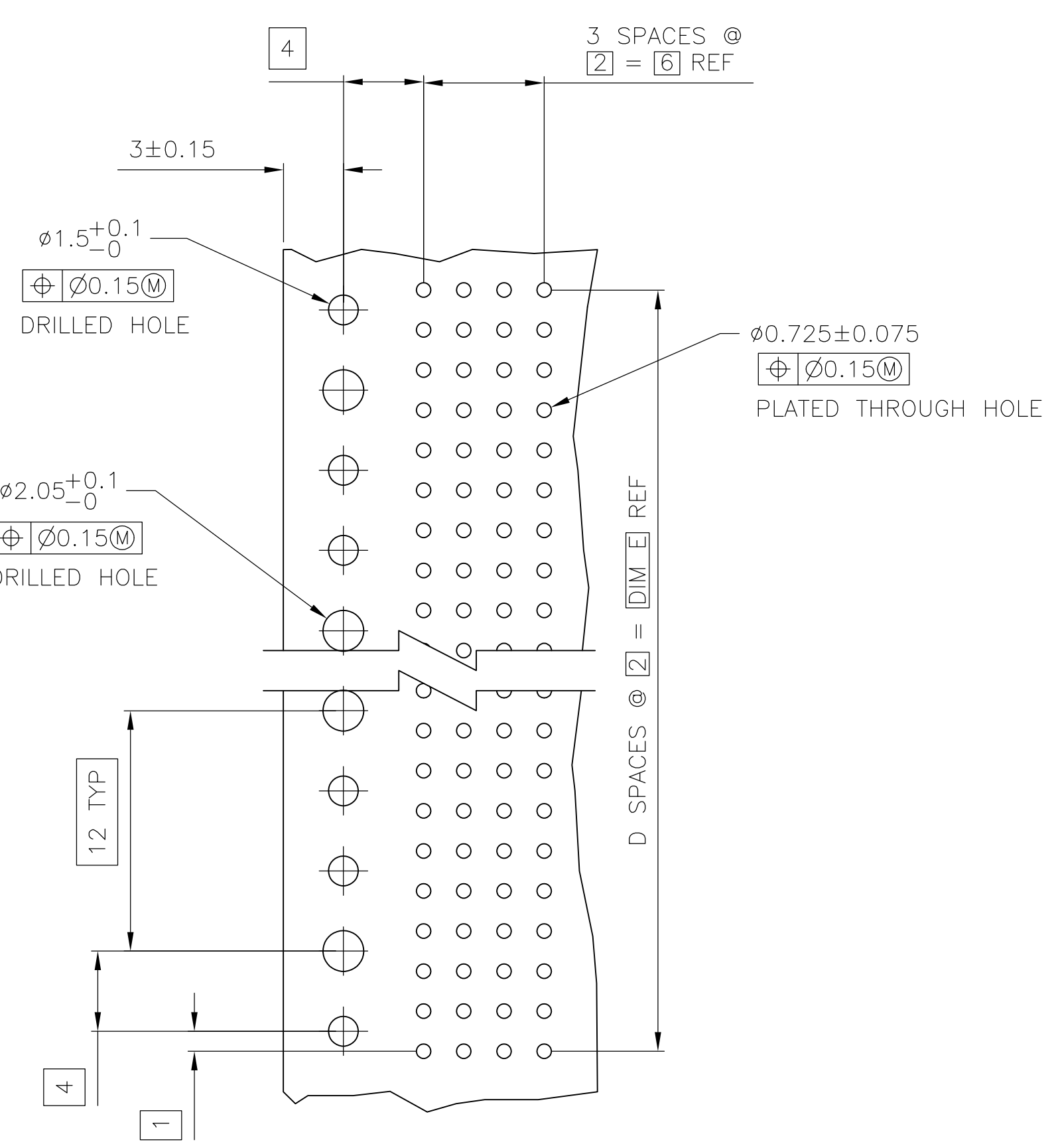

- 1 HOUSING MATERIAL: LIQUID CRYSTAL POLYMER.
- 2 CONTACT MATERIAL: PHOSPHOR-BRONZE.
- 3 CONTACT FINISH:  
 UNDERPLATE (ENTIRE CONTACT):  
 0.00127 MIN NICKEL PER SAE-AMS-QQ-N-290  
 ON MATING SURFACES:  
 FLASH GOLD PER ASTM B 488, OVER  
 0.00076 MIN PALLADIUM-NICKEL OVER UNDERPLATE, OR  
 0.00076 MIN GOLD PER ASTM B 488 OVER UNDERPLATE.  
 ON LEADS:  
 0.00127 MIN TIN-LEAD OVER UNDERPLATE.  
 LUBRICATION (MIN MATING SURFACES):  
 SURFACE CONDITIONER AFTER PLATING.

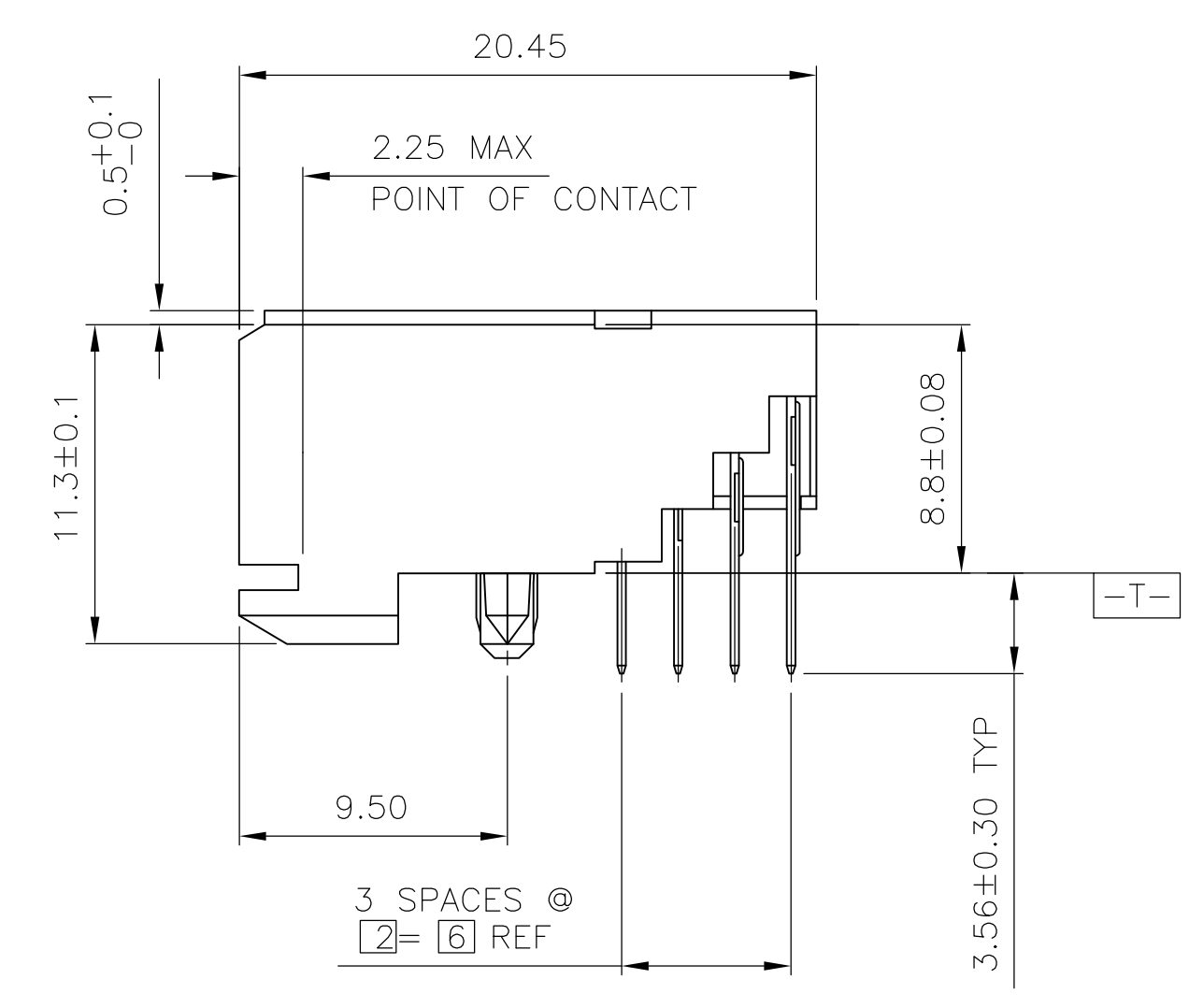
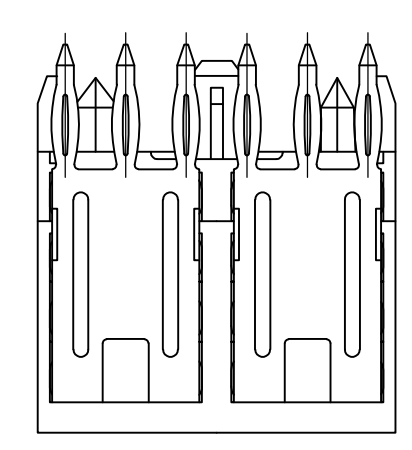
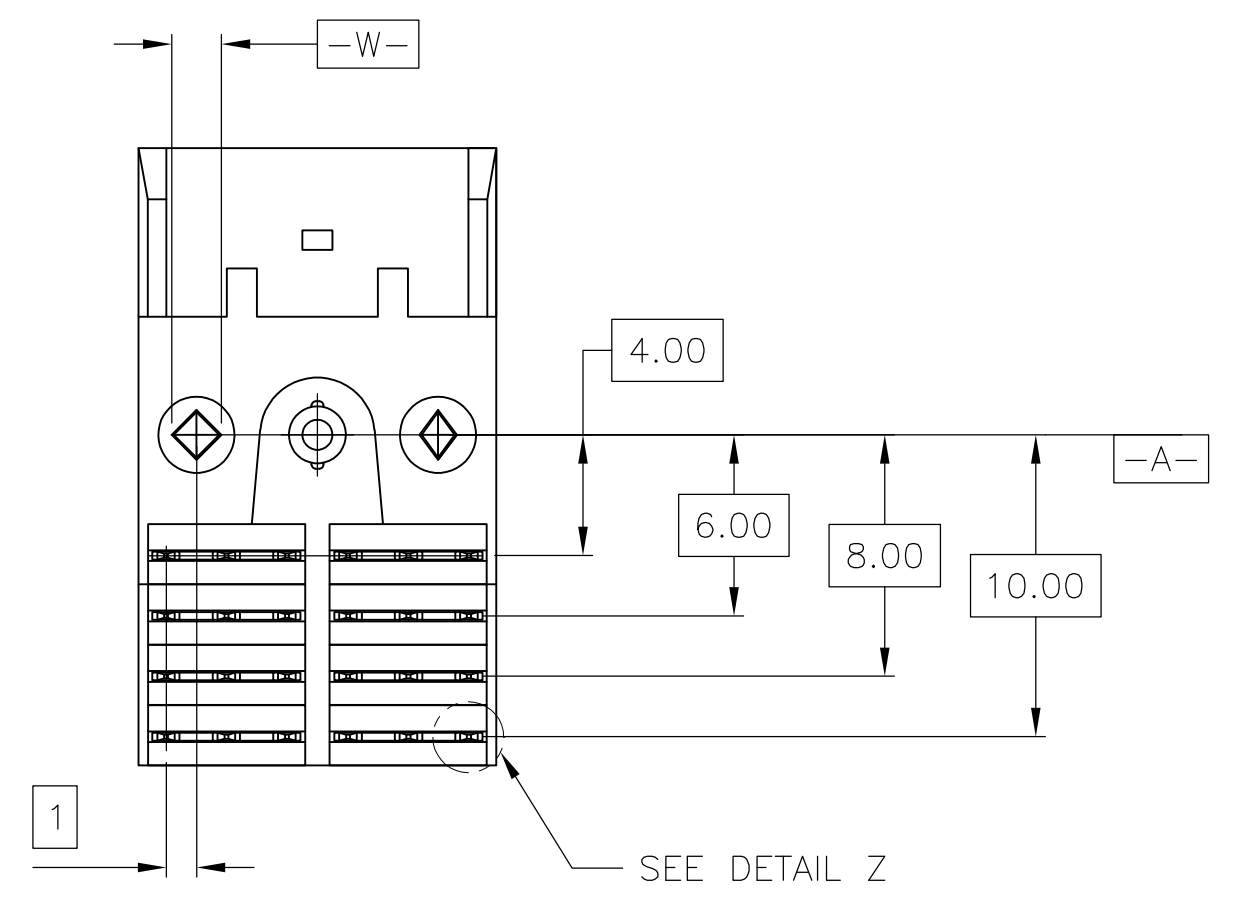
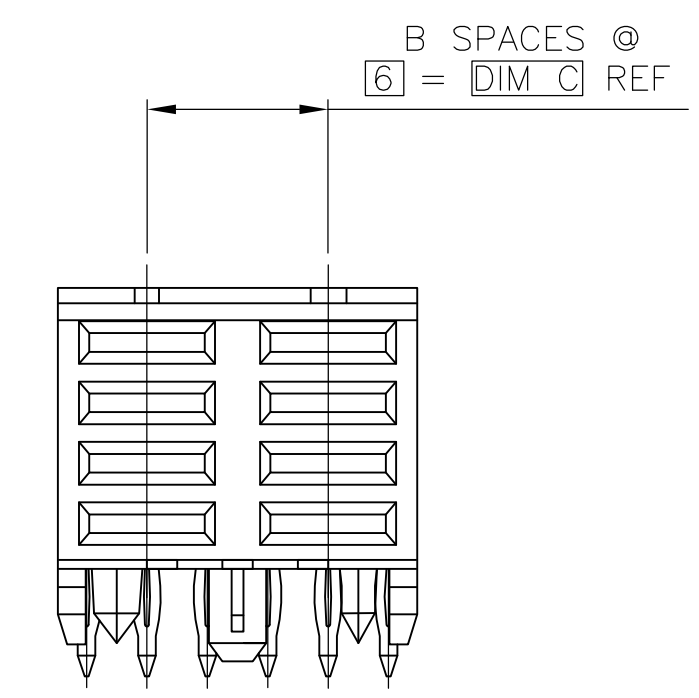
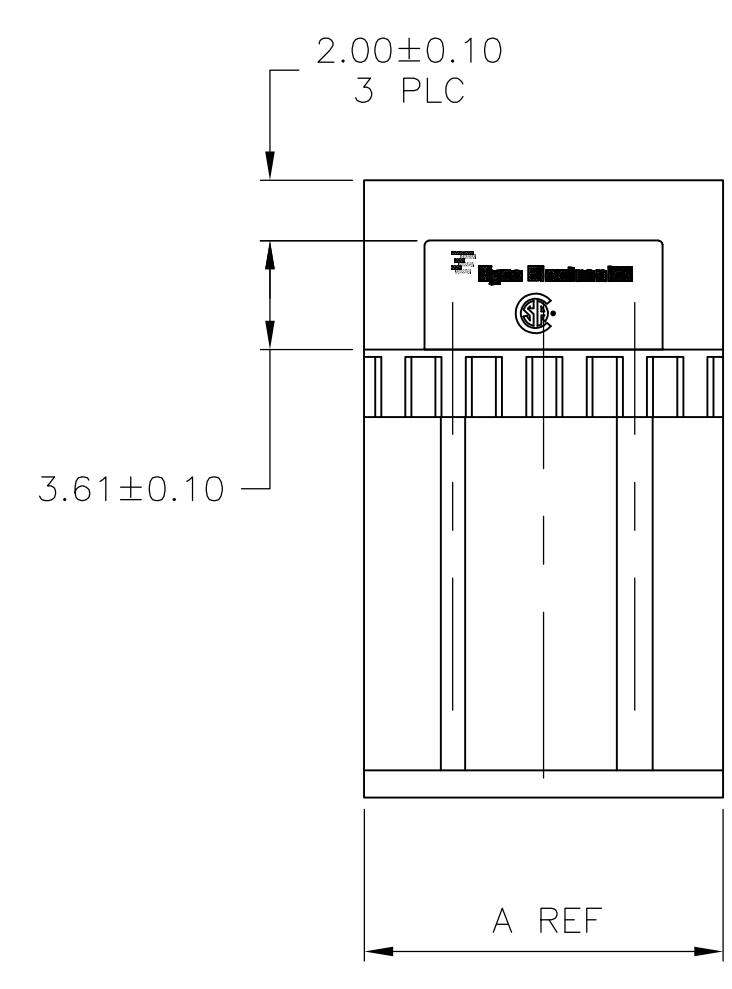
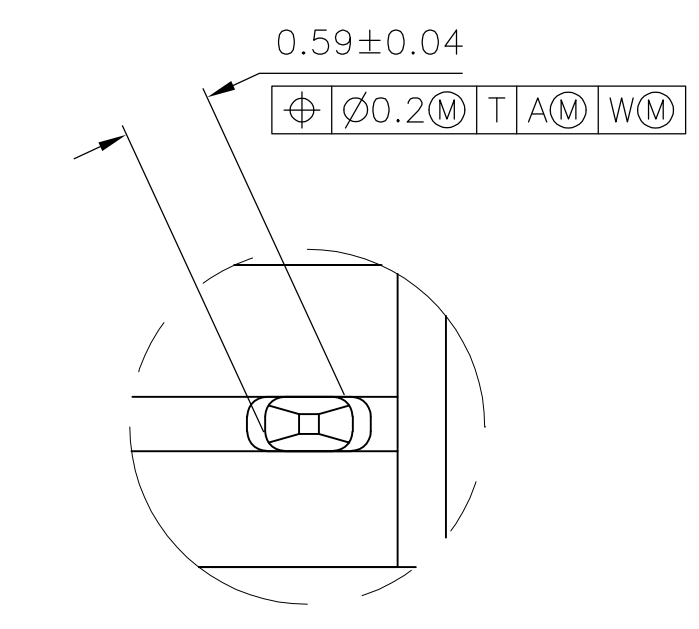

DETAIL Z  
SCALE 20:1

RECOMMENDED CIRCUIT PATTERN  
 PER IPC-D300 TYPE II, CLASS C  
 (COMPONENT SIDE)

10	5	6	1	11.88	3	8	536614-1
E	D	C	B	A	FINISH	NO OF POSN	PART NUMBER
THIS DRAWING IS A CONTROLLED DOCUMENT.		DWN D.R.BENDER 11/04/92		Tyco Electronics Corporation Harrisburg, PA 17105-3608			
DIMENSIONS: mm		TOLERANCES UNLESS OTHERWISE SPECIFIED:		NAME: Z-PACK 2mm FB, POWER MODULE, RCPT. ASS'Y. 4 ROW, 3.56mm LEAD LENGTH			
0 PLC ± -		1 PLC ± -		PRODUCT SPEC -			
2 PLC ± 0.13		3 PLC ± -		APPLICATION SPEC -			
4 PLC ± -		ANGLES ± -		SIZE: A1 CAGE CODE: 00779 DRAWING NO: 536614			
MATERIAL: 1, 2, 3		FINISH: 3		RESTRICTED TO: -			
CUSTOMER DRAWING		SCALE: 4:1		SHEET: 1 OF 1		REV: P2	